



SCAPER EUROPE GMBH

**Die cutting and creasing machine
with hot foil hologram stamping**

model Brausse 1050FH



1

Pictures might be slightly different from reality



Highlights of all Brausse machines

- Extremely smoothly running due to the unique index box drive of the main chain
- All electrical components are off the shelf brand names such as Omron and Siemens
- All PLC controls are from Mitsubishi
- Foil unwinding and advancing system are driven and controlled by high tech Mitsubishi servo motor and driver
- All operating software in the local language
- **This machine can only be operated as a hot foil stamping machine with hologram or normal foil and also normal die cutting and creasing machine**

Standard equipment

General

- Each gripper bar can be individually shimmed to ensure very accurate and smooth sheet transport in case of uneven chain stretching after years of production
- Gripper bar locking levers can be adjusted by micro adjustment screws
- Alloy gripper bars with a hard chrome surface made by special process
- Automatic main chain greasing system
- Radiator cooling for recycling toggle drive lubrication system
- Catwalk with safety rail
- Drawer for spare parts
- Complete lost sheets control throughout the entire machine
- Self diagnostic system with indication on a colour LCD screen
- Modem with telephone connection for online assistance by problems with electronics (customer has to take care for a dedicated telephone line)
- CE certified
- CE standard safety systems for safe operation
- Emergency stop at arm length
- Centre line system
- Machine is standard elevated 200 mm

Feeder

- Suction head with several adjustment possibilities to handle different kind of materials
- Patent turbo spiral air blower pressing foot at feeder head
- Four pick up and four forward suck heads with angle adjustment
- Motorized side adjustment of pallet table. Pile adjustment during production
- Electrical double sheet control
- Fine air blast at lead edge for smooth thin paper transport
- Sheet slow down device of feeder belts to assure accurate position of the sheet to the front lays (electro-pneumatically adjustable)
- Synchronizing device to adjust the sheet positioning to the front lay by hand during production
- Bullet catcher on the feeder entrance
- Side lays on both sides adjustable for push and pull and for paper and carton
- Electronic side lay controls
- Four individually adjustable front lays with dial read out at the operation side of the machine
- Four electronic front lay controls by means of Omron Glasfiber Optik, adjustable two by two
- Frontmark control with adjustable density
- Blowing device for continuous cleaning of the fibre optic heads of the front marks



- Photo sensor safety barrier at pallet table floor level touching point

Die section

- Precision worm gear crank toggle driving system to ensure smooth and dynamic lower platen movement
- Precision stationery upper platen
- Pneumatic push button die chase locking mechanism to ensure safe and operator friendly changing of the die
- Pneumatic clutch/brake for main drive system
- Motorized pressure control (by servo motor)
- Digital die cutting pressure tonnage display with adjustable pressure limit protection
- Seven high precision alloy gripper bar
- High quality pre-stretched gripper bar drive chain
- State-of-art 3 cam index gripper bar drive system to ensure smooth and precise gripper bar intermittent movement
- Torque limit safety clutch to protect the index drive system in case of gripper bar crash
- Double cam driven gripper opener and front lay swing frame for smooth and accurate sheet register
- Air blasting nozzle bar for stretching the thin paper before die cutting

Delivery section

- Automatic delivery with nonstop curtain. This curtain moves into the delivery to catch the arriving sheets during the pile exchange
- Five section brush brake – brake force individually adjustable
- Adjustable air blow bars to slow down the sheets
- Rear and side joggors with easy position adjustment
- Tape inserter with counter
- Photo sensor safety barrier at pallet table floor level touching point

Standard accessories

- One operation platform
- One 5 mm hardened die cutting plate (HRC 45)
- One sandwich plate (one 3,5 mm base plate plus one 1,5 mm thin plate – hardened HRC 45)
- One honey comb
- One die chase with quick locking system
- One set of stamping die locking toggle



Hot foil stamping unit

- Four servo motor driven foil advancing shafts each individually programmable for short and long foil stepping
- 99 programmable short pull per shaft. Shaft 1 is for normal foil and the 3 other shafts are for the hologram advancing
- Free standing operation console with industrial pc, touch screen for foil advancing step setting and 12 temperature controllers for the heating with pre-heating timer
- Calculation program for optimal foil consumption
- Automatic temperature lowering system (adjustable pro zone)
- Device for easy foil leading trough the machine
- 45° turning bars for transporting the rest foil out of the machine
- Foil splitting blade for cutting the rest foil into several strokes
- Foil break detection at the platen entrance
- Automatic foil consume registration system with “end of foil” warning system
- Oil cooled foil tension shaft for optimal foil web control
- Thin paper stretching air blower with adjustment of air volume, strength per zone and start and stop timing
- Foil separating system with adjustment of air volume, strength per zone and start and stop timing
- Foil drawing system for foil change outside the machine
- Brush roller system for removing the waste foil and controlling the web tension





Specifications

Power / air

- Power voltage 400 V / 50 Hz
- Power supply for main motor 11 kW
- Power supply for additional motors 9 kW
- Power supply for heating 24 kW
- Power supply for additional motors and drives 19 kW
- Total power supply including heating 63 kW
- Air supply / consumption 6 bar / 1200 l per min

The compressed air quality must be according to ISO 8573/1

- Filtration on solid parts class 4
- Filtration on oil class 4
- Dry air class 4

General specifications

- Pile height feeder, maximum 1530 mm (incl. pallet)
- Pile height feeder with non-stop operation, maximum 1130 mm (incl. pallet)
- Pile height delivery, maximum 1300 mm (incl. pallet)
- Pile height over non-stop curtain maximum: 80 mm
- Total length (incl. preloading rails) 7060 mm
- Total width (incl. operation platform) 4730-5530 mm
- Total height (incl. raise 200 mm) 2225 mm
- Total net weight 16,5 t

5

The lowest drive-through height between loading area and the machine installation place:

without elevation	2450 mm
with 100 mm elevation	2550 mm

The smallest width in the distance between loading area and machine installation place:

without elevation	2200 mm
with 100 mm elevation	2200 mm

Specifications material

- Maximum sheet size 1050 x 750 mm
- Minimum sheet size 400 x 360 mm
- Processable materials
 - 1. Paper (depending on quality), min. 80-90 g/m²
 - 2. Carton (depending on quality), up to (*) 1600 g/m²
 - 3. Corrugated board (fine), up to (*) 4 mm
 - 4. Plastic materials, like PP, PE 0,6 mm
- (*) admissible undulation: 4% of the sheet width
- Minimal gripper edge 9,5 mm



Specifications for die cutting

- Maximum die cutting size 1040 x 720 mm
- Inner size of chase 1080 x 745 mm
- Dimensions die cutting plate 1080 x 736 mm
- Maximum die cutting pressure 300 t
- Maximum mechanical speed 7500 sheets/h

Specifications hot foil stamping unit

- Foil advancing shaft 1
- Foil advancing shaft for hologram 3
- Maximum capacity foil diameter Ø 240 mm
- Foil core diameter 1" or 3"
- Maximum foil and stamping size 730 x 1020 mm
- Maximum foil stamping speed (subject to paper, foil and stamping die quality as well as operator's skills)
 - Foil pull length ≤ 200 mm Foil width ≥ 100 mm 6000 sheets/h
 - Foil pull length ≤ 300 mm Foil width ≥ 100 mm 5000 sheets/h
 - Foil pull length ≤ 600 mm Foil width = 150 mm 4000 sheets/h
 - Foil pull length 600-700 mm Foil width = 150 mm 3500 sheets/h
- Register tolerance in running and cross direction ≤ 0,2 mm
- Max. mechanical speed 7500 cycles/h
- Maximum hologram foil stamping speed (subject to paper, foil and stamping die quality as well as operator's skills)
 - Foil pull length ≤ 100 mm Foil width ≥ 40 mm 5000 sheets/h
 - Foil pull length ≤ 300 mm Foil width ≥ 40 mm 4000 sheets/h
 - Foil pull length ≤ 500 mm Foil width ≥ 40 mm 3000 sheets/h
 - Foil pull length ≤ 100 mm Foil width ≥ 20 mm 3000 sheets/h
- Maximum foil stamping speed with minimum foil width 20 mm (subject to paper, foil and stamping die quality as well as operator's skills)
 - Foil pull length ≤ 200 mm Foil width ≥ 20 mm 4000 sheets/h
 - Foil pull length ≤ 600 mm Foil width ≥ 20 mm 3500 sheets/h
- Max. mechanical speed 7500 cycles/h
- Minimum foil width 20 mm
- Hologram stamping accuracy (subject to paper, foil and stamping die quality as well as operator's skills) +/- 0,3 mm
- Number of heated zones 12
- Temperature range 0-200°C
- Power for heating 24 kW

The Brousse 1050FH machine is delivered with the European safety certificate CE. Specifications are subject to change without notice

Independent of the fact whether the machine is placed on ground level or above a cellar, or on a floor, the own oscillation of the carrying floor, including the weight of the machine, must be over 25 Hz. Only a structural engineer is capable to judge whether the floor is in accordance with the needed values, as stated in our floor plan. Only he can be responsible for this.

Advisable options:

Quick change table die chase or honey comb

Extra honeycomb



More available options:

Paper device (for higher speed)

- Two extra blowers in the front of the feeder pile
- Two extra side blowers of the feeder pile
- Simco antistatic device with 2 blowers and 1 bar at feeder entrance
- Mink brushes on the feeder table
- Thin paper stretching air blaster at stripping
- Software change
- Wider front stoppers, left and right

Extra set of locking toggles, 4 sizes, each 20 pcs. US made

Extra set of locking toggles, 4 sizes, each 20 pcs. China made

10 inch touch screen with movable arm

Modified gripper bar locks for a register tolerance in running and cross direction $\leq 0,1$ mm

Die-chase with quick locking system

External rewinder unit with 8 torque driven motors

Semi-automatic foil waste compactor HSM AK 807

Hardened sandwich plate (HRC 48) consisting of 2 plates: 3,5 mm and 1,5 mm

- Hardened change plate 1,5 mm (HRC 48)
- Hardened base cutting plate 3,5 mm (HRC 48)

Hardened die cutting plate 5 mm (HRC 48)

Die cutting plate with 1 mm quick change system

- 1 x 5 mm steel plate with micro adjustment
- 10 extra 1 mm plates HRC 31-33

1 mm plate hardness HRC 31-33 (minimum 10 each order)

Job saver system, consisting of

- 1 x 21,5 mm steel plate with micro positioning pins
- 1 x 6,5 mm plate

6,5 mm plate for job saver system

Thin paper stretching air blaster at stripping

Elevation 100 mm extra

Simco antistatic device with 2 blowers and 1 bar at feeder entrance

Simco antistatic device for the new foil at platen outlet, so foil entrance

Compressor set

- Compressor with integrated air dryer 8 bar 1200 l/m
- Connection air hose

Preloading device mounted at the front of the feeder

Non-stop feeder with automatic pile lift

Paper inserter delivery



1050FH
ELEMENT LAYOUT

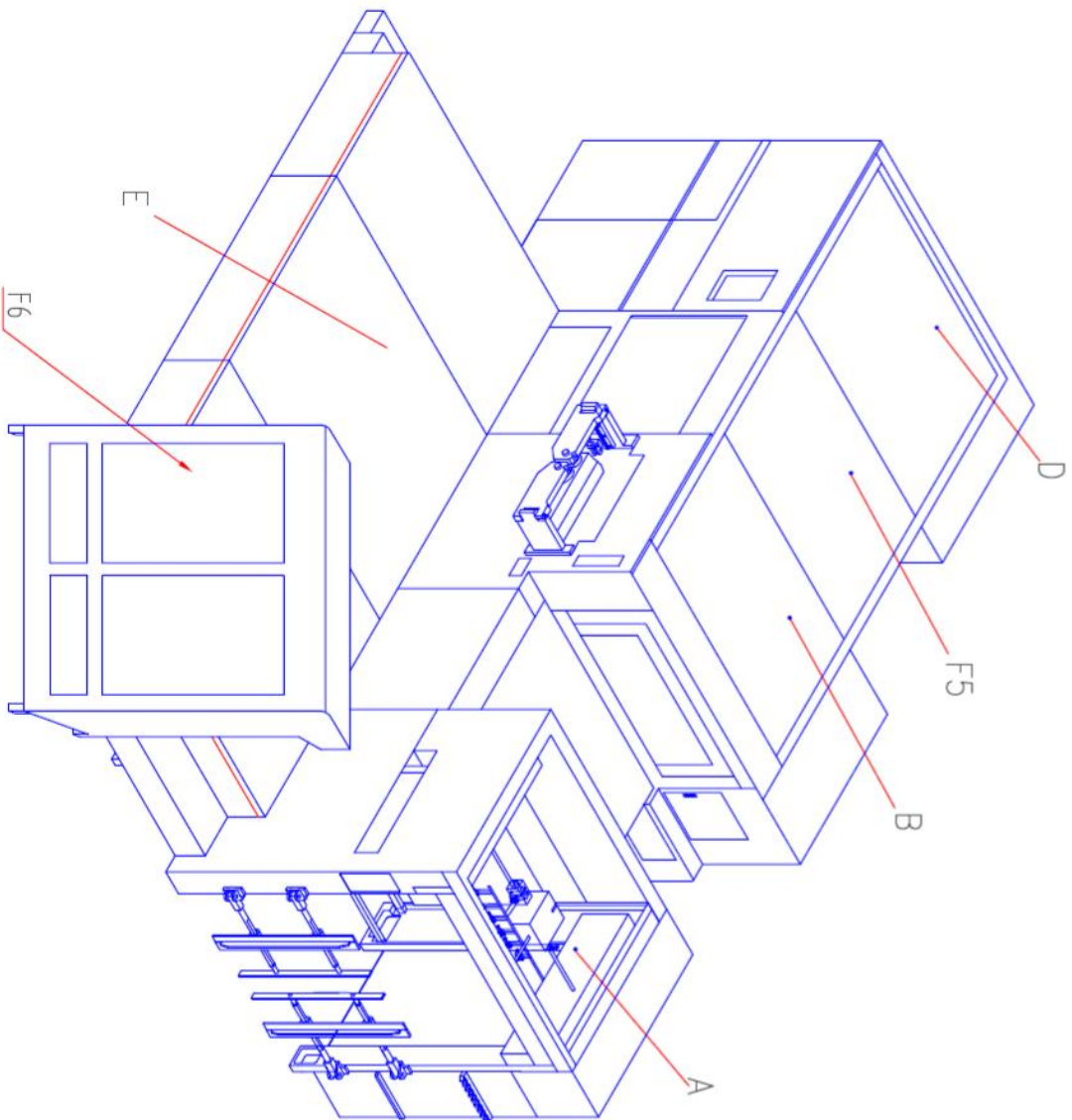



1050FH
DIE-CUTTING STRIPPING MACHINE'S FLOOR PLAN

